

CHME

Horizontal Intelligent
Constant Pressure Variable
Frequency Pump

Nanfang Pump Industry CP.,Ltd

CNP Headquarter
Address: Renhe Town, Hangzhou, China
Post code: 311107
Tel: +86 571 86397876, +86 571 86397827
Fax: +86 571 86397809
E-mail: info@nanfang-pump.com
http: //www.cnppump.com

 CNP

E191101
subject to amendments



Pumping Water Pumping Honor

Stock code:300145

 CNP





Company profile

Founded in 1991, Nanfang Zhongjin Environment Co.,Ltd. (hereinafter referred to as CNP) has been listed on the Shenzhen Stock Exchange on 9th December 2010; Stock name: CNP; Stock code: 300145.

As the first enterprise specializing in the research and large-scale production of stainless steel stamping welded centrifugal pump in China, CNP is currently the professional manufacturer with the highest volume of production and marketing in that industry. It ranks first in the country in terms of product scope, sales volume, and production quality. The company has set up a complete network of marketing services to meet the requirements of overseas markets as well as domestic needs. The products have seen a wide range of application in the area of pressurization, industry, living water, cycling of air-conditioning water, heat supply, fire extinguishing system, pumping of underground water, treatment of sewage and waste water, chemical industry and desalination of sea water etc.

CNP has now entered into the fast track of development and has taken a major step forward in forging China Strong Pump Enterprise and World's famous brand in the Pump Industry. In order to better meet the client's needs and requirements for expansion, it has set up a wide network of selling and service, as well as offices and service centers in major cities in China, which are aimed at providing timely and effective services for our clients. Meanwhile, our company has successfully penetrated into the world market by forging a good business relationship with more than 50 countries and regions in the Europe, Northern American, and Southeast Asia etc.

CONTENT

Performance Range	1
Product Range	1
Product Introduction	2
Motor	2
Controller	2
Function And Features	2
Working Conditions	2
Model Definition	2
Application	2
Curve Conditions	2
Layout Drawing	3
Chme3 Performance Curve、Performance Table	4
Chme5 Performance Curve、Performance Table	5
Chme10 Performance Curve、Performance Table	6
Installation Sketch	7
Dimension And Weight	7

Performance Range

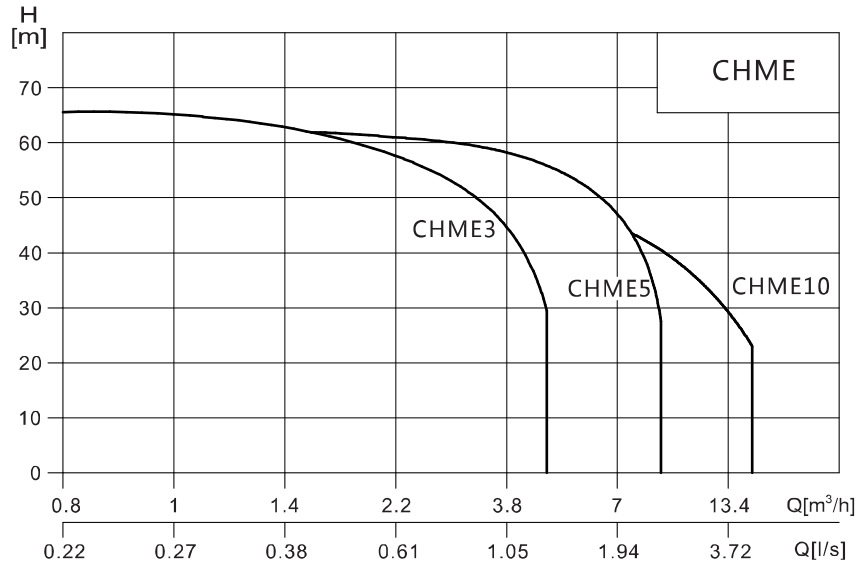

Product Range

Model	Features	CHME		
		3	5	10
Rated Flow [m³/h]		3	5	10
Rated Flow [l/s]		0.83	1.39	2.78
Flow Range [m³/h]		0.8 ~ 5.2	1.3 ~ 10	3 ~ 17
Flow Range [l/s]		0.22 ~ 1.44	0.36 ~ 2.78	0.83 ~ 4.72
Motor Efficiency [kW]		0.37 ~ 1.1	0.55 ~ 1.5	1.5 ~ 2.2
Temperature Range [°C]		-15 ~ 105		
Highest Efficiency [%]		57	67	69
Inlet Pipeline / Outlet Pipeline		G1/G1	G1¼/G1	G1½/G1½

Product Introduction

CHME Series Horizontal Intelligent Constant Pressure Variable Frequency Pump adopts frequency conversion speed regulation technology and automatic control technology. It combines with CHM Non-Self-Priming Light Horizontal Multistage Centrifugal Pump which is high efficient and energy saving. The whole machine is mainly composed of CHM pump, controller, sensor, pressure tank, check valve and axial pressure gauge. It has the characteristics of stable performance, high efficiency, fully automatic intelligent control, low noise, corrosion resistance, with compact structure, beautiful appearance, small size and light weight.

Motor

TEFC secondary motor
Protection class: Ip55
Insulation class: F

Controller

Protection class: Ip55
Input power: 1×220 V 50/60Hz
Frequency variable range: 30~60Hz

Function and Features

Fully automatic operation: It can start and stop automatically according to demand, and can automatically adjust speed according to the water amount to ensure constant pressure and energy saving.

Clean and sanitary: The flow parts are all made of stainless steel to ensure that the water quality will not be contaminated again.

Constant pressure: Keep constant pipeline pressure through Differential Compensation Principle of pressure tank.

Electrical protection: The controller has no protection against overcurrent, overload, and lack-phase. When the controller detects an electrical fault, an inverter fault signal will appear on the display screen and the pump will be automatically shut down to protect it.

Self-set pressure: The pressure can be set by the control panel within the pump performance range.

High efficiency and energy saving: When the user's water consumption is reduced, the controller drives the motor to run slowly, thereby reducing the actual output power of the pump. Compared with the traditional power frequency motor (constant speed), the power consumption of the pump is greatly reduced. This enables users to save power.

Working condition

Liquid temperature: For normal type, -15°C~ +70 °C
For hot water type, -15°C~ +105 °C
Max. ambient temperature: 40 °C
Max. working pressure: 10 bar
pH range: pH5~9

Model definition

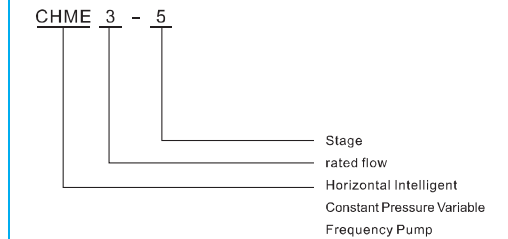

Application

Filtration water system
Industrial water circulation system
Cooling water system
Urban residential home water supply system

Curve conditions

Following conditions are suitable for the performance curves shown above.

- All curves are based on measured values under motor speed 3500rpm.
- Curve tolerance in conformity with ISO9906:2012, Grade 3B.
- Measurement is done with 20°C air-free water, kinematic viscosity of 1mm²/sec.
- The operation of pump shall refer to the performance region indicated by the thickened curve to prevent overheating due to too small flow rate or overload of motor due to too large flow rate.

Layout Drawing

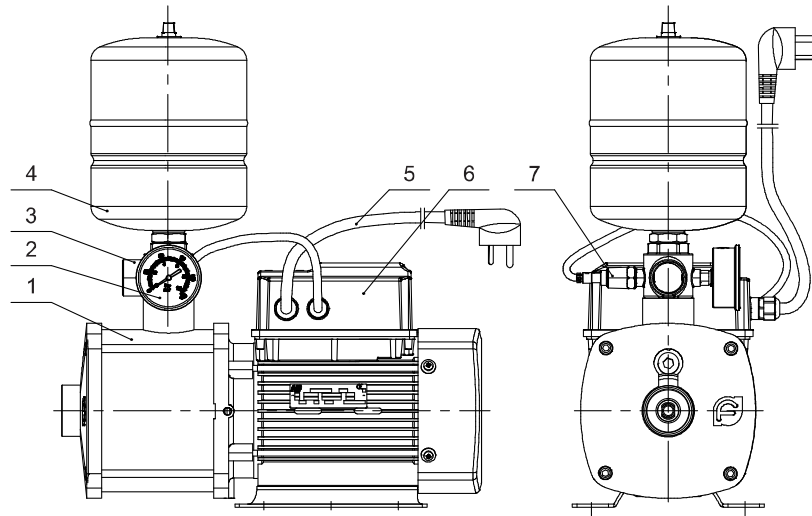

Component Part List

No.	Part Name	Remark
1	CHM pump	Light horizontal multistage centrifugal pump
2	Axial pressure gauge	0 ~ 1.0MPa
3	Five-way check valve	Stainless Steel (AISI304)
4	Pressure tank	
5	Power cable	3×1.5mm ² (10A250V)
6	Controller	0.37 ~ 2.2kW
7	Pressure sensor	0 ~ 1.0MPa

CHME3 Performance curve

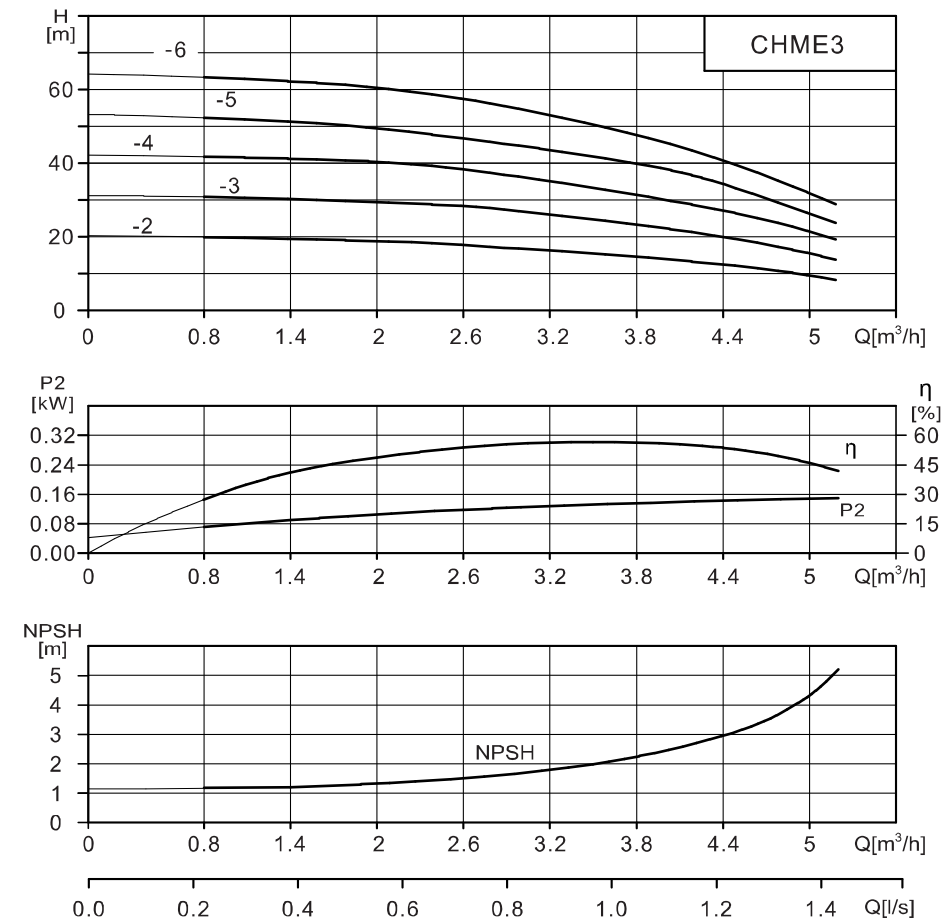

CHME3 Performance table

Model	Matching motor (kW)	Q (m³/h)	0	0.8	1.4	2	2.6	3	3.2	3.8	4.4	5	5.2
CHME3-2	0.37	H (m)	20	19.5	19.3	19	18	17.2	16.5	14.9	12.8	9.8	8.5
CHME3-3	0.55		31	30.5	30	29.2	28.1	26.5	25.8	23.1	19.8	15.3	13.5
CHME3-4	0.75		42	41.5	40.9	40.1	38.1	35.5	34.3	31.2	27	21.3	19
CHME3-5	1.1		53	52.1	51	49.2	46.5	44.2	43.4	39.7	34.2	26.2	23.5
CHME3-6	1.1		63.5	62.5	61	58.4	56	53.5	51.9	46.5	39.6	30.8	27.5

CHME5 Performance curve

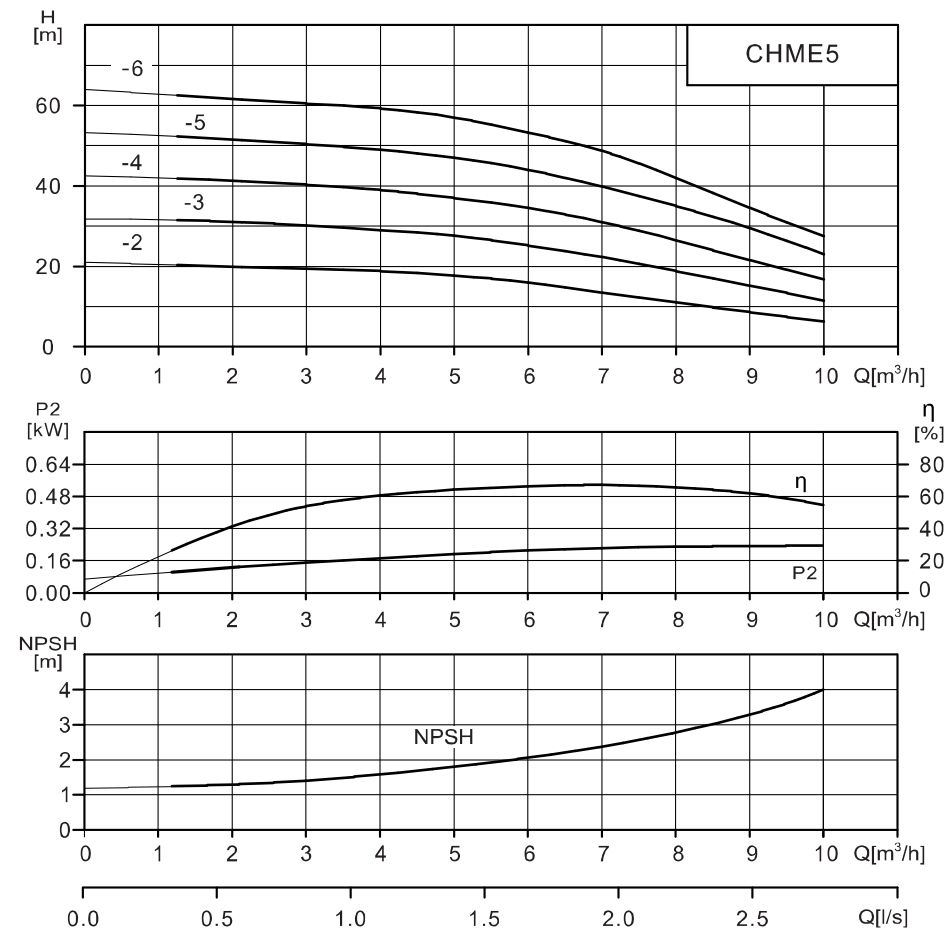

CHME5 Performance table

Model	Matching motor (kW)	Q (m³/h)	0	1.3	3	4	5	6	7	8	9	10
CHME5-2	0.55	H (m)	21.2	20.3	19.4	18.8	17.7	16	13.5	11	8.6	6.2
CHME5-3	0.75		31.8	31.4	30.2	29.3	27.6	25.2	22.3	18.8	15.2	11.5
CHME5-4	1.1		42.5	41.8	40.3	39	37	34.5	31	26.5	21.5	16.8
CHME5-5	1.5		53.3	52.2	50.4	49	47	44	39.8	35	29.5	23
CHME5-6	1.5		64.0	62.4	60.5	59.3	57	53.3	48.7	42	34.5	27.5

CHME10 Performance curve

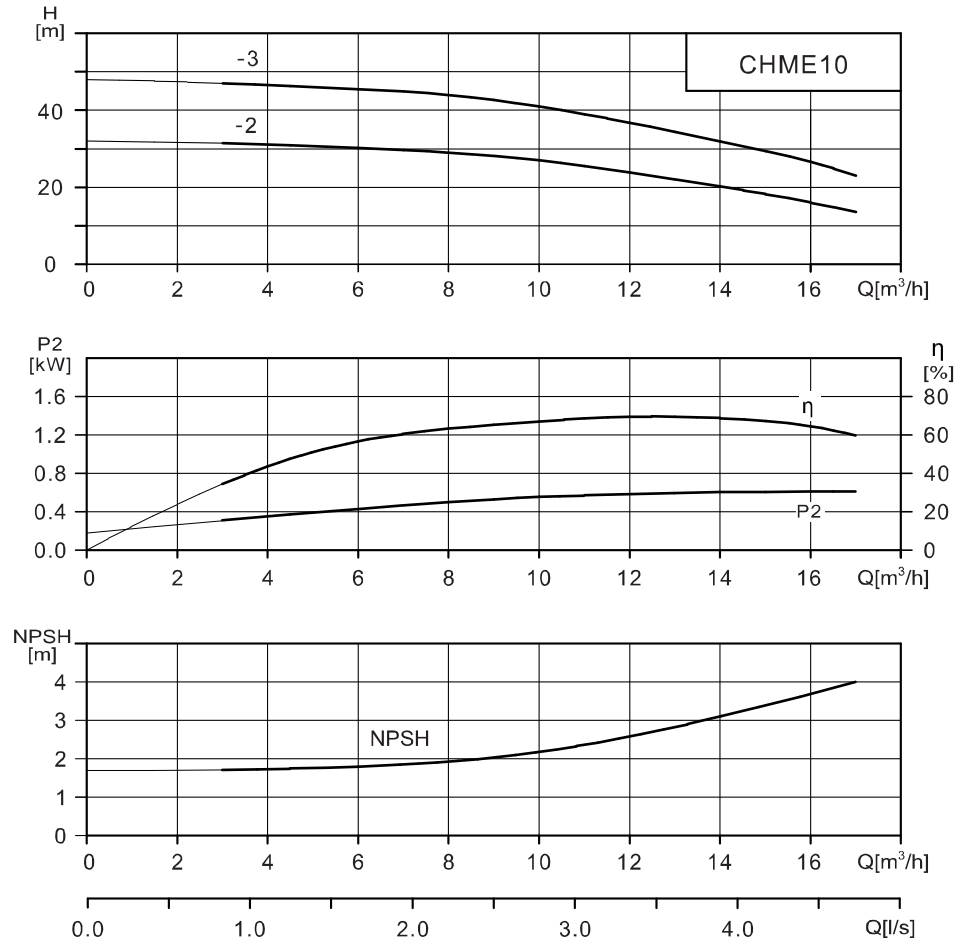

CHME10 Performance table

Model	Matching motor (kW)	Q (m³/h)	0	3	6	8	10	12	14	16	17
CHME10-2	1.5	H (m)	32	31.4	30.2	29	27	23.8	20.2	16	13.5
CHME10-3	2.2		48	47	45.5	44	40.5	36.5	32.5	27	23

Installation Sketch

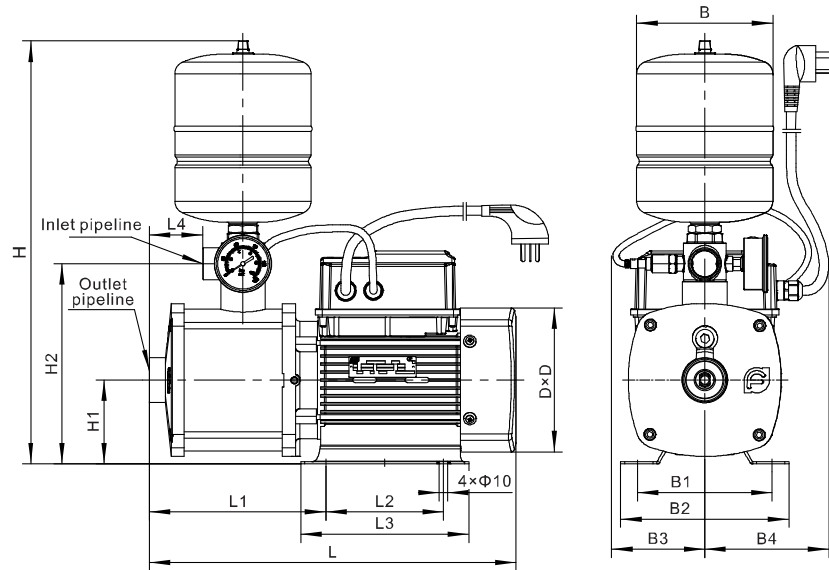

Dimension And Weight

Model	Dimension(mm)														Inlet pipeline/ Outlet pipeline	Weight (kg)
	L	L1	L2	L3	L4	B	B1	B2	B3	B4	H	H1	H2	D		
CHME3-2	328	137	96	150	32	170	125	158	100	105	475	75	165	141	G1/G1	14
CHME3-3	328	137	96	150	32	170	125	158	100	105	475	75	165	141	G1/G1	15
CHME3-4	348	157	96	150	52	170	125	158	100	105	475	75	165	141	G1/G1	16
CHME3-5	401	197	96	160	72	170	125	158	100	115	485	85	175	151	G1/G1	20
CHME3-6	401	197	96	160	92	170	125	158	100	115	485	85	175	151	G1/G1	20
CHME5-2	322	131	96	150	26	170	125	158	100	105	475	75	165	141	G1¼/G1	15
CHME5-3	376	185	96	150	80	170	125	158	100	105	475	75	165	141	G1¼/G1	16
CHME5-4	396	185	96	160	80	170	125	158	100	115	485	85	175	151	G1¼/G1	20
CHME5-5	470	239	96	160	107	170	125	158	100	115	485	85	175	151	G1¼/G1	21
CHME5-6	470	239	96	160	134	170	125	158	100	115	485	85	175	151	G1¼/G1	21
CHME10-2	382	172	96	160	17	200	125	158	108	115	598	100	218	151	G1½/G1½	23
CHME10-3	437	219	140	200	47	200	160	200	108	115	598	100	218	171	G1½/G1½	28